

## Prototype of sugarcane bud chips cutting machine for nursery planting

Mohamed I.M. Ahmad<sup>1</sup>, Galal M.O.A<sup>2</sup>, Osman M.A.M.<sup>3</sup> and Yousif E.M.M<sup>2</sup>.

<sup>1</sup>Agricultural Engineering Research Institute, Agricultural Research Center, Dokki, Egypt.

<sup>2</sup>Agronomy Department, Sugar Crops Research Institute, Agricultural Research Center, Giza, Egypt.

<sup>3</sup>Plant Pathology and Entomology Department, Sugar Crops Research Institute, Agricultural Research Center

(Manuscript received 12 Aug 2020)

### ABSTRACT

The aims of the present work is to introduce a mechanical sugarcane buds separation system for purpose of nursery planting. In current study, the machine was designed, fabricated and tested laboratory at the Agricultural Engineering Research Institute (AENRI), Giza. The field test was conducted in Elmatana Research Station, Luxor Governorate. The machine was developed to cut the cane buds with an adequate part of root band to secure strong germination. The machine used to separate the bud from the cane stalk and leave the stalk for industrial process. The mechanical system consisted of the developed unit that powered by the compressed air provided by an air compressor at a pressure of 10 bar. A pneumatic cylinder pushes a special punch that separates the buds of the cane stalk. The physical and mechanical properties that related to cutting the sugar cane buds were measured. Average production of the machine under the conditions of the test was about 1056 buds/h. Buds sizes were classified according to the part of stalk diameter cut by the punch. The cuts were determined approximately as 1/4, 1/2, and 3/4 of the stalk diameter, and the results showed a high vitality of the seedlings resulting from the separation of buds with this machine. Experiments in the nursery showed that the planting of the buds separated by using this machine gave a high germination percent. Bud chips germination significantly improved after treatment with fungicide (Rizolex-T 50%) for 5 minutes, compared with untreated treatment. Transplanting the healthy seedlings in the permanent field gave high cane yield (60.96 t/fed), which was 10.96% higher than that of conventionally planted cane crop (54.94 t/fed). It also produced higher tiller /clump (11), some millable canes /clump (7) and several millable canes /fed (59.56 thousand/fed) with survival (96.17%). This improved also higher stalk length (262.75 cm), diameter (2.8 cm) and weight (1.28 kg).

**Keywords:** Sugar Cane, transplanting, bud chips, seedlings

### INTRODUCTION

Most of sugar cane cultivation is located in Upper Egypt (Minya, Sohag, Qena, Aswan and Luxor Governorates) More than 30 million farmers and agricultural workers are engaged in growing cane crops. There is an urgent need in Egypt to reduce water consumption in agriculture, Sugar cane is a crop that needs large amounts of water for irrigating. Sugar cane is indispensable as its sugar produces more than 50% of Egypt's sugar needs. It is the base of many other industrial industries and there are in Egypt more than eight factories working in the manufacture of sugar from the reed in Upper Egypt, in addition to the refinery Alhawamedia employs more than ten million workers. The cultivated areas of sugar cane in Egypt harvest season (2018) are 64.25 million Feddan of which sugar cane newly planting 54969 Feddan. There was a problem if the machines available to extract the buds of sugar cane work to break the sugar cane stalk into small pieces so it can't be supplied to factories where the process of supplying sugarcane crop in Egypt depends on the supply of the crop in the full canestalk. It is not possible to deliver sugarcane stalk in the form of small pieces due to the nature of the machines used in the factories. So, in order for the reeds to be delivered, the bud must be taken with a portion of the sugarcane stalk and retain on the full length of the reeds for delivery to the sugar factory. Transplanting practices consider the major target toward applied irrigating water, effect weed control, and uniform plant growth by proper plant spacing.

To obtain this target, transplant production technology is the most wears manual transplanting is very expensive, So the proposed prototype being formulated the propagation of the transplanting technique, a traditional

sugarcane planting in Egypt, consumes about 5-6 tons to Fadan using stalk cutting containing 3 to 4 buds, Galal (2016) Observed that using seedlings from bud chips saved about 97% by weight of stalk material. One choice to diminish the mass and improve the nature of seed cane is plant extracted axillary buds of cane stalks, prominently known as bud chips. These bud chips are less massive, effectively transportable and progressively affordable seed material. The bud chip innovation holds incredible guarantee in fast duplication of new cane varieties. Kiran *et al.* (2016) mentioned that Sugarcane planting with conventional method is exorbitant, tedious and vital pressure of buds in the field isn't accomplished effectively given stalk planting in sugar cane. In the conventional planting method, extraordinary human power and a high volume of sugar cane stalk in hectare are required. Galal (2016) Bud chipping machine was used to prepare bud chips that were planted in trays filled with peat moss and vermiculite mixture, or planted in mini-plots near the permanent planting field. Direct set planting (conventional method) was carried out using three budded cane sets planted directly in the main field on the same date of nursery preparation. They indicated that planting sugarcane using seedlings from bud chips saved about 97% by weight of stalk material. Bud chips planted in trays along with chips planted in mini-plots were statistically higher than conventional methods of sprouting and germination percentage. Seedlings arising on tray recorded higher field survival of 95% as compared to those arising on mini-plot (82.5%) under field conditions. The study showed that bud chip is a viable and economical planting technique for reducing total sugarcane production costs. Mohammad *et al.* (2016) Stated that unlike the expensive acquirement cost of starting planting material, sugarcane planting materials got from tissue culture, an innovation created a countless number of tillers and stalk population per hectare resulting about a high spread rate (1:42.4).

Not with standing the other opportunity benefits, the current outcome indicated that the utilization of tissue cultured seed source is by a wide margin more beneficial than utilizing the regular seed source in terms of the rate of propagation. Patnaik *et al.* (2016) Sugarcane (*Saccharum spp. hybrids*) is planted by cutting of cane stalk known as cane setts. This technique for ordinary sugarcane spread in India has now gotten costly as the expense of seed cane material utilized and amount of seed material required for such planting represents around 20 % of the all-out expense of development. An elective method of utilizing just bud chip holds guarantee to lessen the colossal seed cane, material in business sugarcane planting. In this specific situation, an on-ranch preliminary outcome unmistakably demonstrated that the bud chip innovation gave higher cane yield (106.80 t/ha) as against 92.00 t/ha under ordinarily planted harvest by 3-bud setts, which was higher by 13.86 % over ordinarily planting. Santosha *et al.* (2017) mentioned that sugarcane cultivation process involves many steps in which the extraction of bud saves more than 50% of investment in the cultivation process for the farmer. Thus, the better method of extracting buds from sugar cane is being developed. The Automated sugarcane bud extracting machine has sensors to detect the bud. This bud part is positioned at the workstation using a conveyor system controlled by a stepper motor. The bud is extracted with the help of a pneumatic cutter. The microcontroller is used to control the overall process. This implementation of sensors, stepper motor and pneumatic cutter provide flexibility to the operator who is at the workstation. Also improves the occupancy of the machine. Jayabal and Chockalingam, (1991) Dip the bud chips in fungicides solutions control bud chips infected with *Fusarium spp* and *Colletotricum spp* which leads to an occurrence pre- and post-emergence damping-off for bud chips in a nursery and protecting seedlings from infection by fungi in the main field and increase plant vigour so that stronger transplants can be planted into the field. Also, determine which treatments could be used on a commercial scale to stimulate germination of bud chips. The present study aims to develop a new machine to cut the cane buds with an adequate part of the root band to secure strong germination.

## MATERIALS AND METHODS

### MATERIALS:

#### 1- Machine specifications:

1-1-machine was developed for cutting and separating of buds out of sugarcane stalks. The machine separating the bud with adequate part of root bound to be used planting either in plastic or in the nursery soil. The Prototype Construction Bud Extraction Machine as shown in Fig. (1).

1-2- Cane stalks physical and the mechanical properties were studied and the measure data were; stalk length, stalk weight, stalk diameter and number of buds. The measured cane mechanical properties were; internode hardness, compression strength and bending moment.

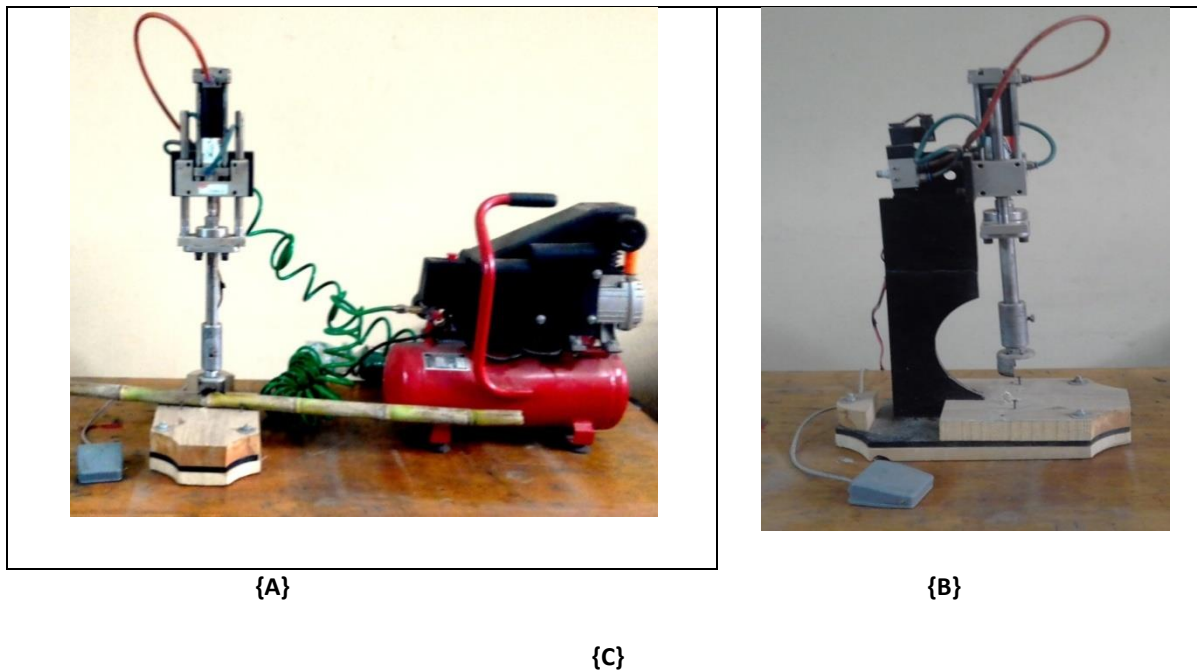
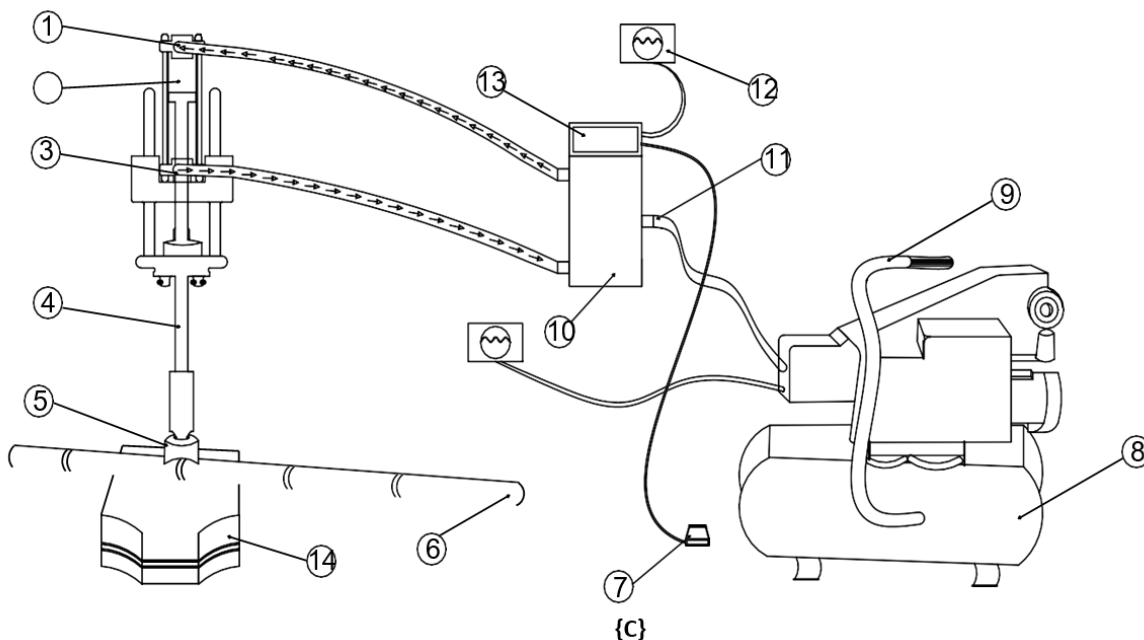

Fig {1(A,B,C)}: The developed machine for bud extraction



- 1- Air inlet.      5- pieces.      9- Hand.
- 2- Cylinder.      6-Sugar cane stalk.      10-Control Box.
- 3- Air out.      7- Feet switch.      11- Air inlet from the compressor.
- 4- Compression rod      8-compressor      12- Electric control.

It bud separation unit vertical column fixed to the base that on which a pneumatic cylinder is mounted. A sharp punch was then fixed to the bottom end of the cylinder shaft. The machine is powered by the air force pressure received from a compressor. Single way valve that operated (open and close) by an electric switch was used to operate

the pneumatic cylinder. The switch was located where the operator can press it by feet. A compressor tank of 10 L capacity discharges 126 L/ min compressor was used as a source of compressed air. The specification of the compressor is indicated in Table (1).

Table (1) Air compressor specifications

Model	JD-1510B(F)
Power	1.5 HP
Voltage	220-240V
Frequency	50Hz/60Hz
Current	7.5A/17A
Overall dimensions L,W,H.	52.5*29*62cm
Rated Speed	2850r.p.m./3400r.p.m.
Discharge	126L/min
Max. working pressure	115psi
Tank Capacity	10L
Net weight	12kg

As Fig. (2) pneumatic force provided by the pneumatic cylinder may be calculated based on the area of the cylinder piston.

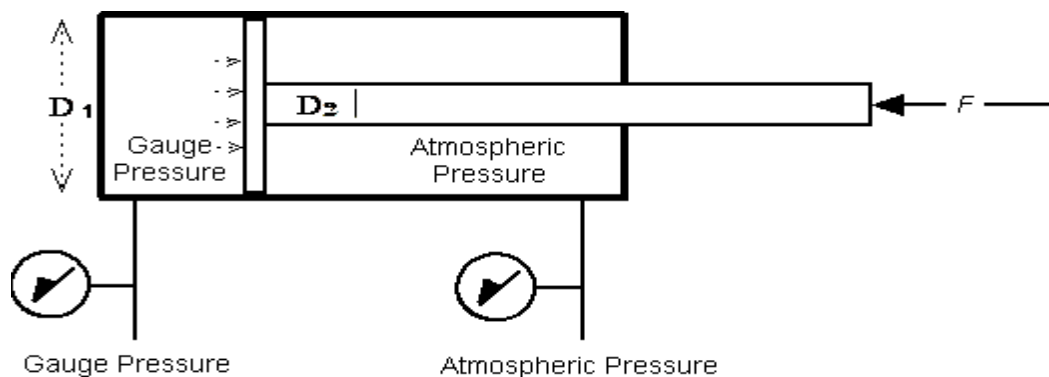

Fig(2): Diagram draw of cylinder.

The cutting and separating force are computed as following equation:

**the force provided supposed to be**

$$F = A * P * 0.9 \text{ kg} \text{ ----- (1)}$$

$$A = \pi D^2 / 4$$

Where: F = Force, P = Pressure,  $\pi$  = Pi = 3.14159, A = area, D = full bore piston diameter.

**2- Machine description and performance:**

The labour holds the cane stalk and moves it until the bud became under opposite to the face of the punch, then the labour presses the switch bottom that opens the valve to allow the compressed air to extend the cylinder when the shaft strongly presses the punch down that penetrate the stalk and cut the bud with adequate part of root band. The labour repeats this action to continuously separate the buds. After separating all the buds, the stalk still malleable and could be used for juicing or sugar distillation process.

The machine consists of a vertical shaft on which a punch is fixed on its bottom end. The shaft is connected to a pneumatic cylinder at its top end. The pneumatic cylinder is powered through a pneumatic valve. And the open-close

value action was done using bottom under the labour feet. The labour holds the cane stalk and moves it until the bud became under the face of the punch, then the labour presses the value top that allow the compressed air to stretch the cylinder when the shaft strongly presses the punch down. While the labour repeats this action to continuously separate the buds. Healthy cane stalks, free from attack by insects and diseases were selected and cleaned manually from leaves. Experienced labour was also assigned to operate the machine. The labor holds the cane stalk and moves it in a special grove under the cutting punch. When a bud is opposite to the punch, the labor press the switch bottom where the punch strongly stretches down and cut the bud. The force of cutting provided by the machine was calculated as indicated.

## METHODS:

### Machine performance evaluation:

#### 1-Machine productivity:

The machine was operated for 15 minutes employing experienced labour. The cut buds were counted, then the machine productivity was computed as No.bud/h.

To compute the average productivity of the machine. For trails were repeated where the average productivity was computed in bud/h.

#### 2-Bud size and percent of germination:

The cut buds were classified into 3 sizes in reference to stalk size. Bud sizes were classified according to the part of stalk diameter cut by the punch. The cuts were determined approximately as 1/4, 1/2, and 3/4 of the stalk diameter. The size of the bud expected to influence on germination, so that experiments were conducted to determine percent of germination for all cut sizes.

#### 3-Field experiments:

Sugarcane bud chips of commercial variety G.T 54-9 separated by the bud cutting machine were planting in a nursery that was established in 1<sup>st</sup> of March 2019 in El-Mattana Research Station (latitude of 25.25°N and longitude of 32.31°E), Agricultural Research Center, Luxor Governorate, Egypt. Bud chips were planted in polyethylene bags Placing bud chips in an upright position after fungicide treatment Fig. (3). Sugarcane bud chips were soaked for five minutes in the Rizolex-T 50% fungicide (Table, 2) which was mixed with distilled water at the recommended dose. The control bud chips were deeps in distilled water at the same time. The inducing effect of fungicide on the germination of sugarcane bud chips was also studied. Healthy seedlings were transplanted into the well-prepared field after the 45<sup>th</sup> day (mid-April) Fig. (4). 60 seedlings were planted per plot at a distance of 35 cm. Conventional method (direct set planting) was carried out using 72-3 budded sets/plot in the main field at the same date of nursery provision and harvested on the mid-April 2020. A randomized complete block design with 6 replications was used for the experimentation. The experimental plot area was 21 m<sup>2</sup> (comprised 3 rows of 1 m apart and 7-m long).



Fig.(3) Placing bud chips in an upright position in poly bags



Fig (4). seedlings germination after 45<sup>th</sup> day of planting.

Table (2): Form of fungicide tested include commercial name, Common name and concentration, chemical name and recommended dose /Liter of water.

Commercial name	Common name and Concentration	Chemical name	Dose /Liter of water
Rizolex-T	Tolclofos-methyl 20% + Thiram 30%WP*	O-(2,6-dichloro-p-tolyl) O,O-dimethylphosphorothioate (IUPAC). 20% Tetramethylthiuram disulfide(IUPAC).30%	2g

\*(WP=wettable powder)

#### Data recorded in the nursery:

- Bud chips germination% after 15, 30 and 45 Day.

#### Data recorded in the main field:

- Seedlings survival % and % cane bud germination in conventionally on 40<sup>th</sup> day after planting fig. (10).
- Number of tillers/ clump.
- Number of millable cane/clump.
- Cane stalk length (cm).
- Cane stalk diameter (cm).
- Cane stalk weight (kg).
- Number of millable cane 1000/fed.
- Cane yield (t/fed.)

## RESULTS AND DISCUSSION

### 1-The air pressure used for cutting:

A preliminary test was done to determine the adequate air pressure of the compressor that provides sufficient force to the cutting punch for clean cutting. The pressure regulation valve was adjusted for pressure range from 8 to 10 bar. So that the machine was tested at pneumatic pressure 8 and 10 bar respectively. During the test, it was observed that the pneumatic pressure of 10 bar was better in view of clean cut.

### 2-Physical and mechanical properties:

Tested samples of 68 stalks had taken after a cut and calculated as indicated in the Table (3) stalk length were ranged from 1.55 to 2.6m. Stalk Wight ranged from 1.6 to 2.3 kg and stalk diameter ranged from 1.7 to 3 centimetres. A number of the buds par stalk was also ranged from 9 to 17 buds on the stalk. Data also indicated in Figures (4), (5), according to fig. (1) the shear forces determined at a pressure of 8 and 10 bar. The shearing force at 8 bar resalted not clean cut of stalk with deteriorated edge and unsuitable for planting. The effective shearing force detected at pressure 10 bar.

Table ( 3) Stalk physical properties.

Frequency of Stalk Wieght (No.)	Average of Stalk Wieght (K.g)	Average of Stalk Length (cm)	Average of Stalk diameter	Number of Bud/Plant
8	1.6	155	2.03	9
4	1.7	180	1.8	11
8	1.8	210	1.76	12
12	1.9	220	2.53	13
8	2	225	2.6	14

4	2.1	225	2.7	14
4	2.2	250	2.7	15
8	2.3	250	2.8	15
8	2.4	255	3	16
4	2.5	260	3	17

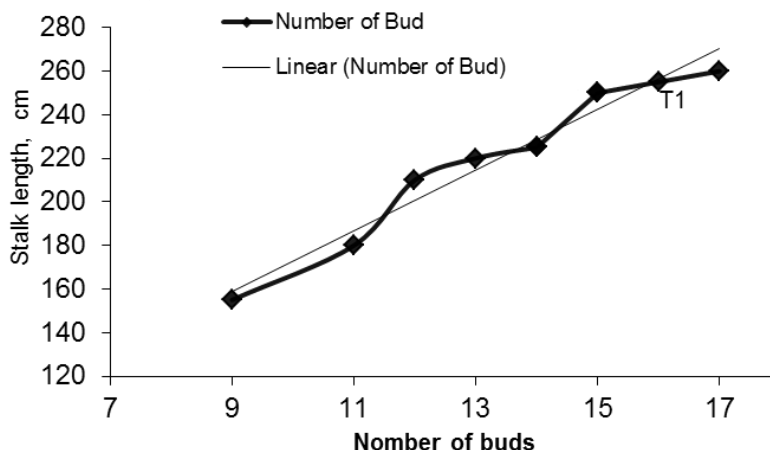

Fig. (4) the relationship between stalk length and numbers of buds.

It is noticed that by increasing the cane stalk length, No. buds increases, Fig (4)

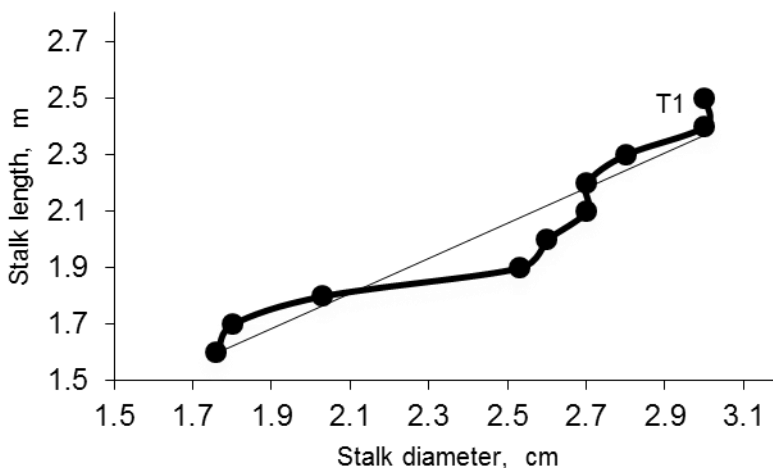

Fig.(5) The relationship between stalk length and mean stalk diameters.

Also by increasing the stalk length cane stalk diameter increases. Fig (5)

**3-Cane mechanical properties:**

As indicated in Table (4), The measurements of cane sample show that intimate hardness was 325 N for the 1<sup>st</sup>Raton and 452 N for second Raton. Compression strength was 4180 N for 1<sup>st</sup>Raton and 4200 for the 2<sup>nd</sup> Raton. Finally, the bending moment showed 840N for 1<sup>st</sup>Raton and 855 N for 2<sup>nd</sup> Raton It is maybe due to incrsiyy the stalk hardness in 2<sup>nd</sup> raton than 1<sup>st</sup> raton.

Table (4): cane mechanical properties.

Cane stalks properties	New Crop	First Raton
Inter- node hardness, N	325	452
Compression strength, N	4180	4200
Bending moment (breaking load, N)	840	855

It is selected the material of cutting and separation unit mechanical properties is bigger than the mechanical properties of cane stalk.

#### 4-Machine productivity:

The machine was operated for 15 operation minutes employing an experienced labour. The cut buds were counted then the machine productivity was computed as bud/h. To compute the average productivity of the machine, four trials were repeated where the average productivity was computed in bud/h. Productivity of the machine ranged from 2,5 to 5 seconds/bud. Accordingly, the productivity ranged from 12 to 24 bud/min and in average 17.4 bud/min. Operating the machine for a complete operation hour, the productivity may be ranged from 720 to 1440 bud/h. Average production of the machine under the conditions of the test was about 1056 buds/h. Table (5) show the results of machine operation.

Table (5): Machine productivity.

Stalke N.	No. of buds	Time Second	Productive bud /second	Bud/min	Bud/h
1	5	14	0.36	21.4	1284
2	9	31	0.29	17.6	996
3	6	21	3.5	17.14	1028.5
4	8	30	0.29	15.8	948
5	6	30	0.45	12	720
6	3	8	0.38	22.5	1350
7	10	40	0.20	23.5	900
8	11	28	0.39	24	1414.29
9	10	31	0.32	19.35	1161
10	9	28	0.32	20	1200
11	7	29	0.24	15	900
12	12	46	0.26	15.8	948
13	10	37	0.27	16.22	973
14	13	50	0.26	15.8	948
15	9	38	2.4	14.3	858
16	12	36	0.33	15.4	924
Average			0.36	16.942	1012



**5-Separated buds properties:**

The measurements of separated buds after a separation show that the bud wight ranged from 8.5 to 14.7g. Length of the chip included buds range from 18.6 to up to 50 mm. width of the bud was also ranged from 13 to 26.8mm. A number of roots on the root band of the cut. Fig. (6) show the sizes and shapes of the cut buds. The characteristics of the bud may be easy to be recognized from the photos in Fig.(7)



**Fig(6) : Bud chips and cane stalks after scooping bud chips.**



**Fig. (7): Buds, bud germination and stalk after bud separation.**

**6-Germination:**

Bud size is shown linked relationship to germination the cut buds were classified into three sizes in reference to stalk size. Tested samples of 100 buds had taken after a cut and calculated as indicated. The operator was oriented to vary the cut buds as 1/4, 1/2 and 3/4 of the stalk diameter. The percent of germination was counted for each treatment. Table (6) and Figure (8) show separated nuds

Table(6): Separated buds properties.

Frequency of Bud	Wight(g)	Length (mm)	Width (mm)	Root nods No.	Germination %
12	13.5	24	21.8	11	90%
9	10.5	18	19.2	8	87%
10	12.1	20	19.4	9	89%
14	16.7	55	32	18	99%
10	10.5	19	18.2	6	80%
7	14.4	40	23.7	17	98%
9	11.5	20	20	10	89%
11	15	40	25.8	15	97%
10	16.5	35.1	26.3	14	96%
8	14.5	31.2	22.6	13	93%

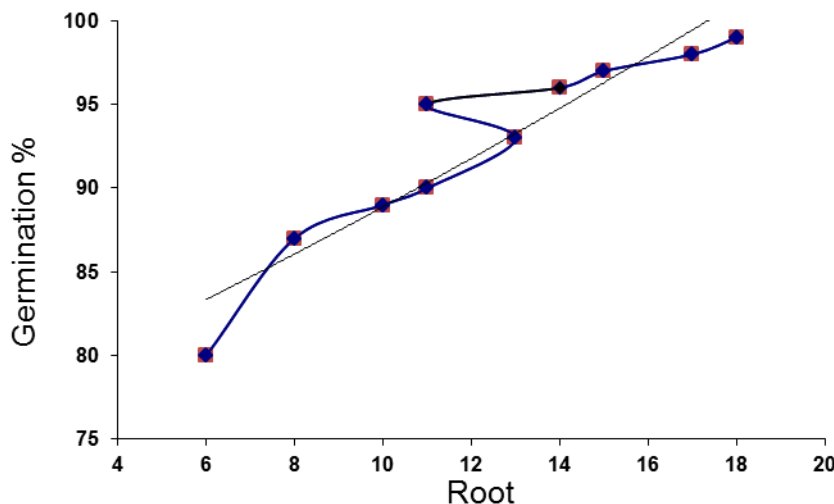

Fig: (8): Percent of germination of cut buds.

Normally, 5The data of this study shows that bud chip technology could a practical and efficient option in lessening the expense of sugarcane creation, if fundamental precautionary measures are taken in taking care of and capacity of bud chip seed material and their resulting increase in the field to 6 tons of sugarcane is required to plant a feddan of land if 16800 three budded sets are used. However, if bud chips are used only 150-200 Kg of material is sufficient which results in a saving of about 90-95% of cane by weight. This is economical in terms of the crop cultivation costs. It also saves several thousand tons of raw material that could be used for extracting sugar. Galal (2016) Indicated that planting sugarcane using seedlings from bud chips saved about 97% by weight of stalk material. Vinod Gound (2011) reported that seed cost can be reduced up to 85%. previous investigations built up that about 80% by weight of the sett-planting seed material can be spared by planting bud chips.

**6.1. Bud germination percentage in nursery:**

*Fusarium* stem rot cause a reddish-brown discoloration (Fig.9) of internal stalk tissues (**Way and Goebel 2003**).



Fig. (9): Bud chips cuttings of sugarcane cultivar G.T. 54-9 infected with seet or steam rot organism, showing Purple –red and reddish-brown discoloration in vascular bundles extending through the nodes and internal of stalk tissues.

The young roots redden by infection with *Fusarium* species, turn purple and decay, or development is prohibited (Fig.10). Buds swell slightly but fail to germinate causing reduced yield and quality of cane (Ahmad and Malik, 1994).



Fig. (10): Bud chips cuttings of sugarcane cultivar G.T. 54-9 infected with seet or steam rot organism, show young roots redden, turn purple, decay and no root development.

Data in a table (7) indicated that the treatments of bud chips with fungicide (Rizolex- T 50%) for 5 minutes significantly improved germination% at 15, 30 and 45 days after planting, compared with untreated treatment (control). Fungicides affect germination of sets and subsequent growth of the plants. Determine fungicides in nursery improve the viability and vigour of the setts and resultant plants (Jayabal and Chockalingam, 1991 and Goodall, 1998). Rizolex-T fungicide inhibition of phospholipids biosynthesis, leading to inhibition of germination of spores and growth of fungal mycelium (Hefnawy *et al.* 2014).

Table (7): Changes in germination of bud chips raised settlings in response to fungicide treatments in sugarcane.			
Treatment	Germination of buds (%)		
	15 DAP	30 DAP	45 DAP
Without fungicide (Control treatment)	34.17	63.50	74.33
With fungicide (RizolexT50%)	48.00	75.08	94.77
LSD 5%	2.54	3.12	2.36

## 6.2. Seedling survival in the permanent field:

Data on survival percent of seedlings created through bud chip innovation and germination rate of cane buds in conventionally planted were looked at and are introduced in Table (8). The outcomes indicated that the seedling survival as shown in Fig. (11) was 96.17 % in bud chip innovation when contrasted with just 68.00 % bud germination in ordinary planting, making a stamped distinction in initial plant population density which is eventually answerable for a higher number of millable cane in bud chip innovation contrasted with a traditional method. This was in agreement with the findings of VinodGound (2011) reported such improvement in the germination of chips.

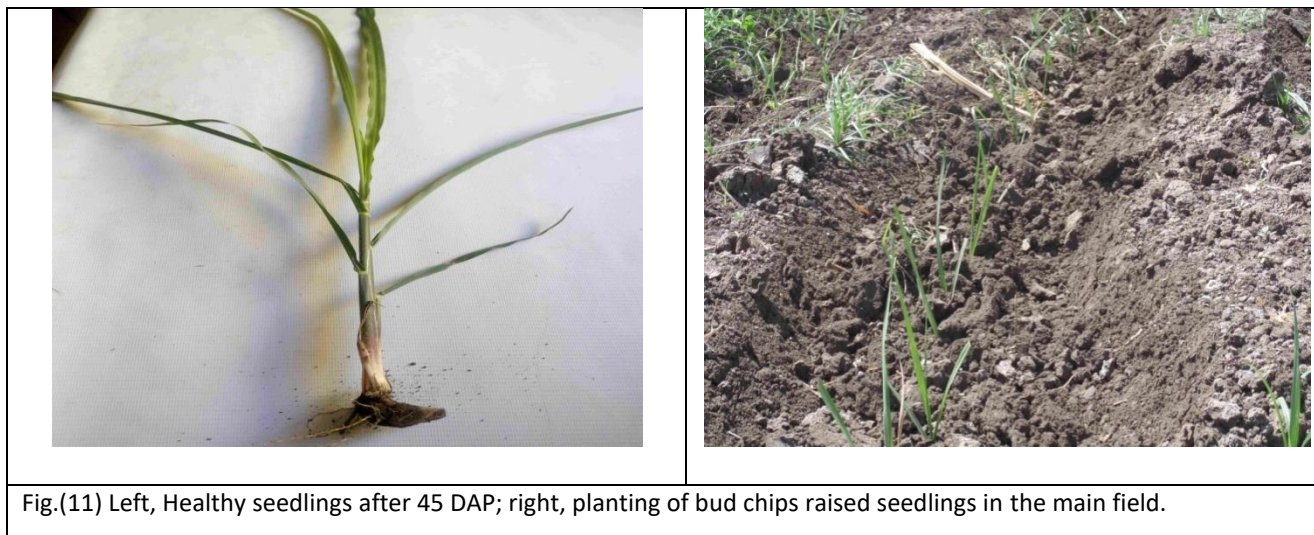

Fig.(11) Left, Healthy seedlings after 45 DAP; right, planting of bud chips raised seedlings in the main field.

## 7. Growth and Yield Components

Data in Table (8) show that bud chip planting innovation created especially higher Number of tillers/ clump (11) at 120 DAP and Number of millable canes /clump (7) at harvest when contrasted with 7 and 4, Consecutively, got under conventional method for sugarcane planting. Stalk length and diameter of cane were likewise higher in bud chip planting innovation when contrasted with a conventional method. Length and diameter of cane stalks in bud chip innovation were 262.75 and 2.80 cm, separately, when contrasted with 244.50 and 2.76 cm in a conventional method for planting. Starting higher plant population on account of optimal spacing must have enjoyed the benefits of conjunctive use of chemical and bio-fertilizers at the tillering stage which saved the way for higher yield attributing characters in bud chip planting innovation (Mohanty 2014).

Table (8): Growth and yield of sugarcane grown through bud chip technology and conventional planting methods

	Survival (%) at 45 DAP	Number of tillers/ clump at 120 DAP	Number of millable canes /clump	Stalk length (cm)	Salk diameter (cm)	Stalk weight (kg)	Number of millable canes 1000/fed	Cane yield (t/fed)
<b>Bud chips</b>	96.17	11	7	262.75	2.80	1.28	59.56	60.96
<b>Conventional</b>	68.00	7	4	244.50	2.76	1.16	48.83	54.94
<b>LSD at 5% level</b>	1.64	0.67	0.42	4.52	NS	0.03	2.80	0.44



## 8. Yield

Data given in Table (8) and fig. (12) indicate that number of millable canes were also higher (59.56 tan/fed.) in bud chip innovation when contrasted with traditional planted (48.83 tan/fed.) which clearly endorses the result of higher number of millable canes/clump under bud chip innovation. Normal stalk weight was 1.28 kg in bud chip innovation when contrasted with 1.16 kg in conventional method of planting. Higher beginning plant population along with higher yield attributing traits resulted in higher cane yield of 60.96 t/fed. in bud chip innovation which was 10.96% higher than traditional method.



Fig.(12). Survival of bud chips raised settling in main field Conclusion

Bud chip technology could a reasonable and practical option in lessening the expense of sugarcane creation if vital safeguards are taken in dealing with and storage of bud chip seed material and their ensuing multiplication in the field. Normally, 5 to 6 tons of sugarcane is required to plant a feddan of land if 16800 three budded sets are used. However, if bud chips are used only 150-200 Kg of material is sufficient which results in a saving of about 90-95% of cane by weight. On the other hand, this technique also saves three full irrigations that may represent up to 10-15% of the total water consumption of the crop. Also, it gave an 11% higher cane yield compared to a conventional method. This is economical in terms of the crop cultivation costs. It also saves several thousand tons of raw material that could be used for extracting sugar. This agri-technology method would immensely help sugarcane breeders to handle with their important cane genotypes with less risk, guaranteed survival, and a great foundation. Moreover, moving the bud chips rather than entire stalks from one area to others would extraordinarily diminish its cost and help in the propagation of new and improved cane varieties. This design aims at simplifying the bud removal process by making use of the above-mentioned machine which requires minimum human labour, less capital investment and saves time thus proving to be a profitable investment for every farmer.

## REFERENCES

- Ahmad, M. and K. B, Malik. (1994). Seed transmission of pokkah boeng and its effect on the yield of sugarcane. *Pat J. Phytopathol.* 6: 21-25.
- Galal, M. O. A. (2016). A new technique for planting sugar cane in Egypt. *IIOABJ*, 7(4);15-21
- Gokhale (1977). A new approach to cane seed nurseries. Sugar technologists Association of India. sixth joint convention,. 163-166.
- Goodall, j. I. (1998). Factors affecting germination and growth of sugarcane transplants, master of science in the Department of Microbiology and Plant Pathology University of Natal Pietermaritzburg,. 170.
- Hefnawy, M. A.; O. A, Eisa. and N. M. El-Feky. (2014). Impact of the fungicide rizolix t50% on the antagonistic activity of *Trichoderma harzianum* and *Trichoderma koningii*. *International Journal of Science and Research (IJSR)*, (3): 9, 1767- 1773.
- Iqbal, M. T. E.; S. U. K. Sufzal. And F. Rukshana. (2002). Performance of sugarcane bud chip settlings. *Indian J Sugarcane Technol* 17: 88.
- Jayabal, V. and S. T. I. Chockalingam. (1991). Studies on the effect of dipping cane setts in chemical solutions on the yield and quality of sugarcane, *Ind. Sug.* 40: 883-885.
- Kiran, B.; B. Ajit and C. Akash. (2016). Automated sugarcane node cutting machine via image processing. *International Journal of Advance Research in Science and Engineering*, 5(12): 233- 237.

- Mohammad, I.; T. Belay; A. Jamal and N. Tadesse (2016). Evaluation of tissue culture raised Sugarcane Planting materials against their donor conventional seed sources as initial source of seed cane at tendaho sugar Development Project, North-Eastern Ethiopia. *Journal of Horticulture* Vol. 3, (1), 1000168.
- Mohanty, M., and P.K. Nayak. (2011). Economizing seed cane quantity by reducing sett size and bud number with sett treatment in sugarcane cultivation. *Indian Journal of Sugarcane Technology* 26(2): 59–60
- Narendranath M. (1992). Cost-effectiveness of transplanting nursery raised sugar cane bud chip plants on commercial suger plantations. *Pro 11<sup>th</sup> Intersoc Sugar Cane Technology*, poster paper, :332.
- Prasad RV, Sreenivasan (1996). Developing technology for sugarcane varietal exchange through bud chips. *Indian J sugarcane technol* 11 :25-28.
- Santosha, S. R.; K. T. Ashwini ; S. L. Anand ; J. Pavan and N. A. Kiran (2017). Automated sugarcane bud extracting machine. *Journal of Emerging Technologies and Innovative Research (JETIR)*. Volume 4, Issue 02, JETIR (ISSN-2349-5162).
- Tamil selvan N. (2006) sugar cane response to chip bud method of planting inter soc sugar cane technol, *Agronomy work shop, khon kaen, Thailand*, :23-26.
- Vinod Gound (2011) *Sustainable Sugarcane Initiative, SSI - A Methodology for improving yields*. pp: 9-12.
- Way, M. J. and F. R. Goebel (2003) Patterns of damage from *Eldana saccharina* (Lepidoptera: Pyralidae) in the 836 Eur J Plant Pathol (2015) 141:825–837 South African sugar industry. *Proceedings of the South African of Sugar Technologists Association*, 7: 239– 240.
- (1) [https://www.engineeringtoolbox.com/pneumatic-cylinder-force-d\\_1273.html](https://www.engineeringtoolbox.com/pneumatic-cylinder-force-d_1273.html)

## نموذج آلة لفصل براعم قصب السكر لزراعة المشتل

محمد إبراهيم محمد أحمد<sup>1</sup>، محمد عويس أحمد جلال<sup>2</sup>، محمد عبد الغنى محمد عثمان<sup>2</sup>، عبيد مصطفى<sup>2</sup>

1- معهد بحوث الهندسة الزراعية – مركز البحوث الزراعية.

2- معهد بحوث المحاصيل السكرية – مركز البحوث الزراعية

تهدف هذه الدراسة الى إدخال نظام ميكانيكى لفصل براعم قصب السكر لغرض زراعة المشتل. فى الدراسة الحالية تم تصميم و تصنيع واختبار آلة مصنوعة محليا فى معهد بحوث الهندسة الزراعية – مركز البحوث الزراعية – الدقى – الجيزة – مصر , كما تم إجراء الإختبارات الحقلية بمحطة البحوث الزراعية بالمطاعة – محافظة الأقصر. آلة فصل براعم قصب السكر المفردة تم تصميمها و تصنيعها و تقييمها محليا. تم تطوير الآلة لفصل براعم قصب السكر مع جزء مناسب من الشريط الجذرى لضمان انبات قوى. تستخدم الآلة لفصل البرعم عن ساق قصب السكر مع ترك باقى الساق للعملية التصنيعية. يتكون النظام الميكانيكى من الوحدة المطورة التى تعمل بطاقة الهواء المضغوط الذى يوفره كميريسور هواء عند ضغط 10 بار. تقوم الإسطوانة الهوائية بدفع قاطع خاص لفصل البرعم عن ساق القصب ثم دراسة الخواص الفيزيائية والميكانيكية المتعلقة بفصل براعم قصب السكر , كان متوسط انتاج الآلة فى ظل ظروف الإختبار حوالى 1056 برعم/ساعة.

صنفت البراعم حسب الحجم حيث تم قطع البراعم بثلاث أحجام مختلفه 4/1 و 2/1 و 4/3 قطر الساق وأظهرت النتائج حيويه عاليه للشتلات الناتجه من فصل البراعم بتلك الآله . أظهرت نتائج تجارب المشتل أن زراعة البراعم المفصولة باستخدام هذه الآلة فى المشتل أعطت نسبة إنبات عاليه. تحسن إنبات شرائح البراعم بشكل ملحوظ بعد النقع فى محلول مبيد فطرى (Rizolex-T 50%) لمدة 5 دقائق ، مقارنة بالبراعم الغير معاملة . اعطت زراعة الشتلات السليمة فى الحقل المستديم محصول عيدان عالى (60.96 طن/فدان) و هو أعلى بنسبة 10.96% من القصب المنزوع بالطريقة التقليدية (54.94 طن/فدان). كما أنتجت أعلى عدد أشطاء/جورة (11), وعدد عيدان قابلة للعصر/جورة (7), و عدد عيدان قابلة للعصر/فدان (59.56 الف/فدان) مع نسبة بقاء الشتلات (96.17%). و قد أدى ذلك أيضا الى تحسين طول النبات (262.75 سم), وقطر الساق (2.8 سم) ووزن الساق (1.28 كجم).